



# DIN ISO 10889 (DIN 69880) Werkzeugaufnahmen

Toolholders

Porte-outils

Takım Tutucular

## INHALTSVERZEICHNIS / INDEX

Seite / Page

<b>Werkzeughalter / Rohling,rund - Round soft blank</b> Ronde mou blanc - Özel takım yapma amaçlı yarımamul	5.02
<b>Radial Werkzeughalter - Radial toolholder</b> Porte-outil radial - Radyal kater tutucu	5.02 - 5.06
<b>Axial Werkzeughalter - Axial toolholder</b> Porte-outil axial - Eksenel kater tutucu	5.06 - 5.08
<b>Vierkant / Aufnahme - Square toolholder</b> Tige carre- Çok yönlü kater tutucu	5.08 - 5.09
<b>Bohrerhalter E1 - Boring holder E1</b> Porte foret E1 - Takma uçlu drill tutucu E1	5.09 - 5.10
<b>Bohrerhalter E2 - Boring bar holder E2</b> Porte-outil E2 - İç çap toplamama kater kutucu E2	5.11 - 5.12
<b>Spannzangenhalter - Collet holder</b> Porte-outils pour pinces - Pens başlığı	5.13 - 5.14
<b>Bohrerhalter für MK F1 - Holder for morse taper F1</b> Porte foret pour morse F1 - Mors konik tutucu F1	5.15
<b>NC Bohrfutter - NC Drill chuck</b> Mandrin de perçage CNC - NC mandren malafası	5.16
<b>Gewindeschneidfutter - Quick change tapping chuck</b> Appareil à taraduer - Kılavuz çekme başlığı	5.17
<b>Kontrolldorne - Test arbors</b> Mandrin de contrôle - Kontrol mastarı	5.18
<b>Einrichtehalter - Setting-holder</b> Porte outil de réglage - Pozisyon kontrol mastarı	5.18
<b>Hydro - Dehnspannfutter - Hydraulic expansions chuck</b> Mandrins expansibles hydrauliques - Hidrolik takım tutucular	5.19
<b>Schutzstopfen - Protective plug</b> Bouchon de protection - Kör tapa	5.20



DIN ISO 10889  
(DIN 69880)



## Einsatz von Radial-Werkzeughaltern bei linker Spindeldrehrichtung

Insert for Radial Toolholders left Spindle Movement

Emploi de porte-outils radiaux, rotation de broche antihoraire

Fener milinin sol dönüş yönü için radyal tutucu

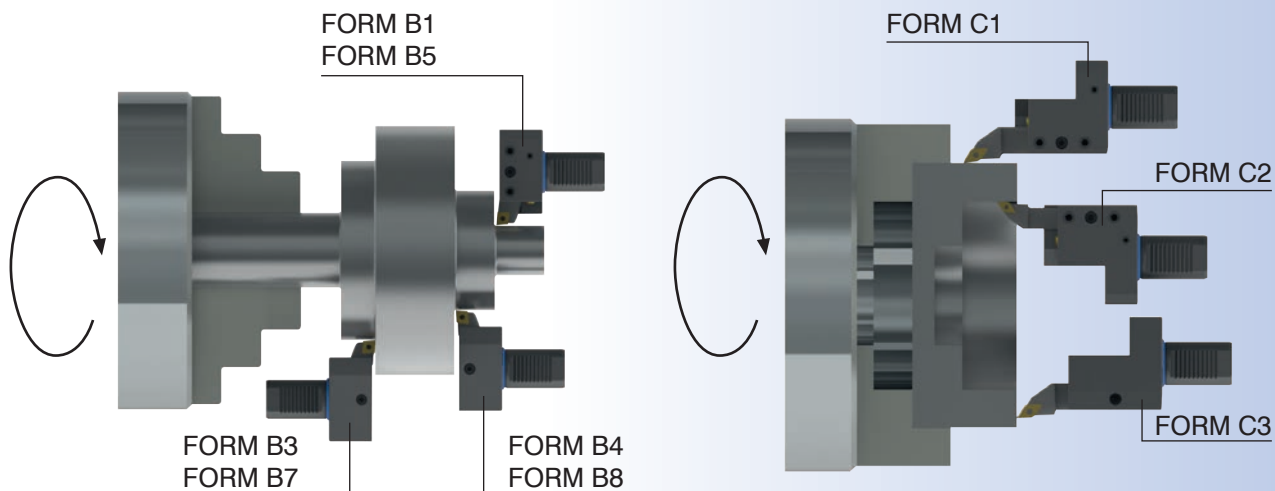

## Einsatz von Radial-Werkzeughaltern bei rechter Spindeldrehrichtung

Insert for Radial Toolholders right Spindle Movement

Emploi de porte-outils radiaux, rotation de broche horaire

Fener milinin sağ dönüş yönü için radyal tutucu

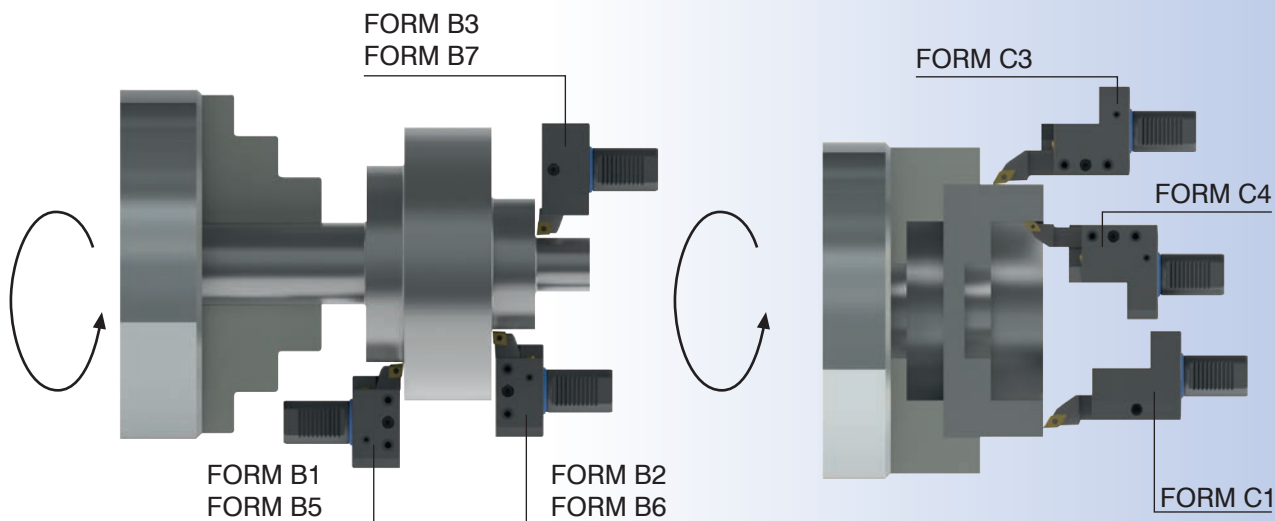

## Toolholders

## Porte-outils

## Şaft ölçüleri

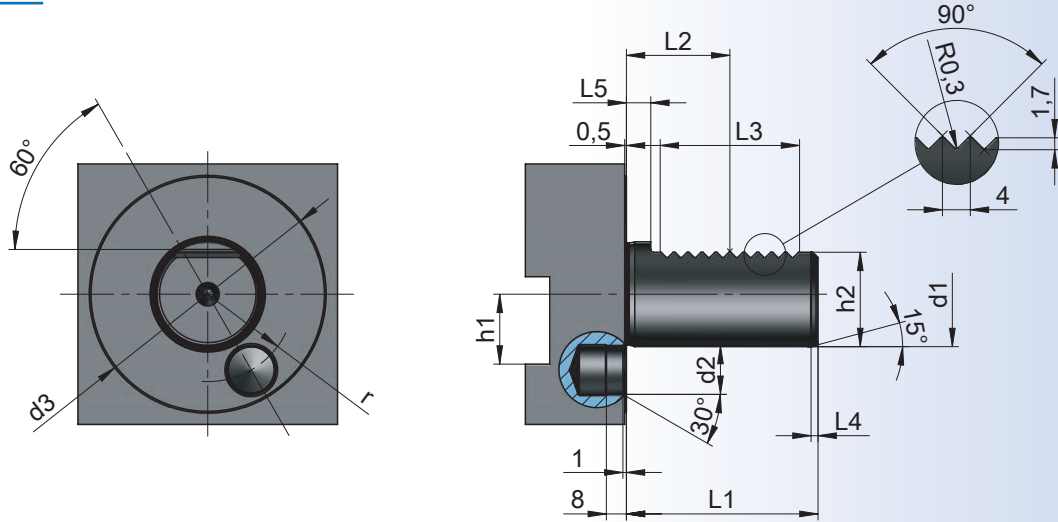

VDI	d1	L1 max.	h1 max.	d2	d3	h2	r	L2	L3 min.	L4	L5
16	16	32	12	8	40	15	14,5	12,7	24	2	3,5
20	20	40	16	10	50	18	18	21,7	24	2	7
25	25	48	16	10	58	23,5	21	21,7	24	2	7
30	30	55	20	14	68	27	25	29,7	40	2	7
40	40	63	25	14	83	36	32	29,7	40	3	7
50	50	78	32	16	98	45	37	35,7	48	3	8

**Ausführung** : Die Werkzeughalter sind aus legiertem Einsatzstahl HRC 52 ± 2 komplett brüniert und präzisionsgeschliffen. Ra 0,3  
Sämtliche Werkzeughalter haben eine große verstellbare Kugelspritzdüse und Gewindeanschluß für Rohrverschraubung, bzw. externer Kühlmittelzufuhr.

**Description** : The tools are manufactured of hardened steel with a hardness of HRC 52 ± 2  
The shaft teeth surface and the holder are grinded. Ra 0,3  
All tool holders have a big movable coolant nozzle and a thread for external coolant.

**Execution** : Les porte-outils sont fabriqués en trempés à HRC 52 ± 2 et entièrement brunis.  
La queue de fixation, la denture, la face d'appui et le logement de l'outil sont rectifiés. Ra 0,3  
Tous les porte-outils ont une bille d'arrosage avec un grand angle d'orientation et un trou taraudé pour un arrosage par externe.

**Teknik özelliği**: Takım tutucular alaşımli çelikten yapılmaktadır. HRC 52 ± 2  
Tamamen siyahlaştırılmıştır ve hassas taşlanmıştır. Ra 0,3  
Bütün takımlarda ayarlanabilir soğutucu gözler mevcuttur.  
Aynı zamanda dıştan soğutma borularının bağlantı dişleri mevcuttur



## Werkzeughalter - Rohling, rund Form A2

A2

Round soft blank, Form A2

Ronde mou blanc (vide), Forme A2

Özel takım yapma amaçlı yarımamul, A2 Formu

DIN ISO  
10889  
(DIN  
69880)

DIN ISO  
10889-2

HRC  
52±2

Bestell-Nr. Order Nr. Référence Sipariş Nr.	Abmessung Size / Dimension Size / Cinsi d1 x L1	L1	d2	Kg	Euro
169.17.40.60	16 x 60	60	40	0,64	
209.17.50.70	20 x 70	70	50	1,16	
259.17.58.80	25 x 80	80	58	1,82	
259.17.58.200	25 x 200	200	58	4,29	
309.17.68.100	30 x 100	100	68	3,10	
309.17.68.240	30 x 240	240	68	7,07	
409.17.83.120	40 x 120	120	83	5,57	
409.17.83.320	40 x 320	320	83	14,01	
509.17.98.135	50 x 135	135	98	9,04	
509.17.98.400	50 x 400	400	98	24,64	

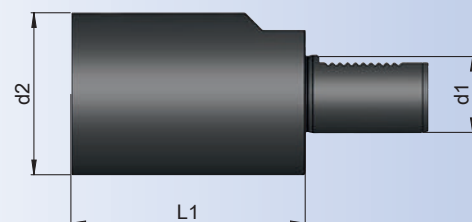

## Radial - Werkzeughalter Form B1 rechts, kurz

B1

Radial - Toolholder Form B1 right, short

Porte - outil radial Forme B1 droite, court

Radyal kater tutucu B1 Formu sağ, kısa

DIN ISO  
10889  
(DIN  
69880)

DIN ISO  
10889-3

HRC  
52±2

Bestell-Nr. Order Nr. Référence Sipariş Nr.	Abmessung Size / Dimension Size / Cinsi d1 x h1 x L2	L1	h5	h6	b1	b2	b3	Kg	Euro
169.31.12	16 x 12 x 24	13	20	22	42	23	5	0,26	
209.31.16	20 x 16 x 30	16	25	30	55	30	7	0,52	
259.31.16	25 x 16 x 30	16	25	30	55	30	7	0,65	
309.31.20	30 x 20 x 40	22	28	38	70	35	10	1,24	
409.31.25	40 x 25 x 44	22	32,5	48	85	42,5	12,5	2,31	
509.31.32	50 x 32 x 55	30	35	60	100	50	16	4,31	

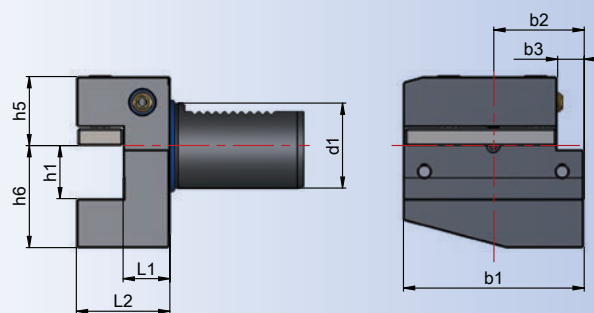

## Zubehör / Accessories / Accessoires / Yedekler



Unterlegplatte  
Shim  
Plaque entretoise  
Kater laması



Kunststoff - Kugelspritzdüse  
Plastic ball sprayer nozzle  
Buse d'injection spherique en plastique  
Su verme misketi

## Radial - Werkzeughalter Form B2 links, kurz

B2



Radial - Toolholder Form B2 left, short

Porte - outil radial Forme B2 gauche, court

Radyal kater tutucu B2 Formu sol, kısa

DIN ISO  
10889  
(DIN  
69880)

DIN ISO  
10889-3

HRC  
52±2

Bestell-Nr. Order Nr. Référence Sipariş Nr.	Abmessung Size / Dimension Size / Cinsi d1 x h1 x L2	L1	h5	h6	b1	b2	b3	Kg	Euro
169.32.12	16 x 12 x 24	13	20	22	42	23	5	0,27	
209.32.16	20 x 16 x 30	16	25	30	55	30	7	0,52	
259.32.16	25 x 16 x 30	16	25	30	55	30	7	0,65	
309.32.20	30 x 20 x 40	22	28	38	70	35	10	1,30	
409.32.25	40 x 25 x 44	22	32,5	48	85	42,5	12,5	2,32	
509.32.32	50 x 32 x 55	30	35	60	100	50	16	4,32	

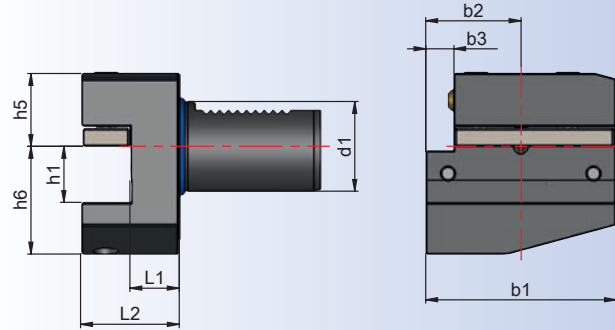

### Zubehör / Accessories / Accessoires / Yedekler



Unterlegplatte  
Shim  
Plaque entretoise  
Kater laması



Kunststoff - Kugelspritzdüse  
Plastic ball sprayer nozzle  
Buse d'injection spherique en plastique  
Su verme misketi

## Radial - Werkzeughalter Form B3 Überkopf rechts, kurz

B3

Radial - Toolholder Form B3 Overhead right, short

Porte - outil radial Forme B3 inversé droite, court

Radyal kater tutucu B3 Formu ters sağ, kısa

DIN ISO  
10889  
(DIN  
69880)

DIN ISO  
10889-3

HRC  
52±2

Bestell-Nr. Order Nr. Référence Sipariş Nr.	Abmessung Size / Dimension Size / Cinsi d1 x h1 x L2	L1	h5	h6	b1	b2	b3	Kg	Euro
169.33.12	16 x 12 x 24	13	22	20	42	23	5	0,26	
209.33.16	20 x 16 x 30	16	30	25	55	30	7	0,52	
259.33.16	25 x 16 x 30	16	30	25	55	30	7	0,67	
309.33.20	30 x 20 x 40	22	38	35	70	35	10	1,27	
409.33.25	40 x 25 x 44	22	48	42,5	85	42,5	12,5	2,40	
509.33.32	50 x 32 x 55	30	60	50	100	50	16	4,50	

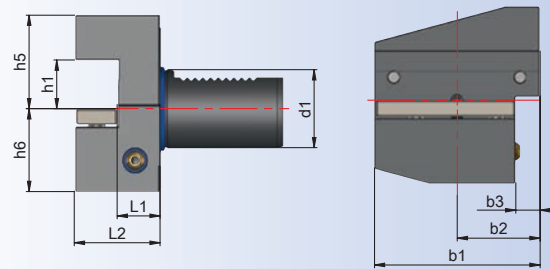

### Zubehör / Accessories / Accessoires / Yedekler



Unterlegplatte  
Shim  
Plaque entretoise  
Kater laması



Kunststoff - Kugelspritzdüse  
Plastic ball sprayer nozzle  
Buse d'injection spherique en plastique  
Su verme misketi

DIN ISO 10889  
(DIN 69880)



## Radial - Werkzeughalter Form B4 Überkopf links, kurz

B4

Radial - Toolholder Form B4 Overhead left, short

Porte - outil radial Forme B4 inversé gauche, court

Radyal kater tutucu B4 Formu ters sol, kısa

DIN ISO  
10889  
(DIN  
69880)

DIN ISO  
10889-3

HRC  
52±2

Bestell-Nr. Order Nr. Référence Sipariş Nr.	Abmessung Size / Dimension Size / Cinsi d1 x h1 x L2	L1	h5	h6	b1	b2	b3	Kg	Euro
169.34.12	16 x 12 x 24	13	22	20	42	23	5	0,36	
209.34.16	20 x 16 x 30	16	30	35	55	30	7	0,53	
259.34.16	25 x 16 x 30	16	30	35	55	30	7	0,76	
309.34.20	30 x 20 x 40	22	38	35	70	35	10	1,29	
409.34.25	40 x 25 x 44	22	48	42,5	85	42,5	12,5	2,41	
509.34.32	50 x 32 x 55	30	60	50	100	50	16	4,60	

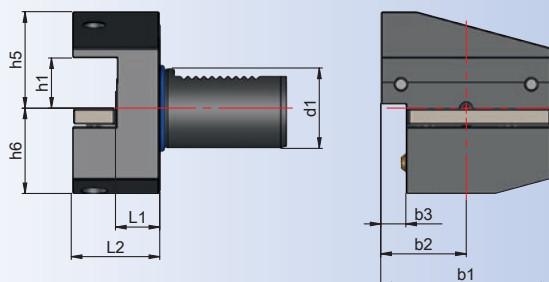

### Zubehör / Accessories / Accessoires / Yedekler



Unterlegplatte  
Shim  
Plaque entretoise  
Kater laması



Kunststoff - Kugelspritzdüse  
Plastic ball sprayer nozzle  
Buse d'injection spherique en plastique  
Su verme misketi

## Radial - Werkzeughalter Form B5 rechts, lang

B5

Radial - Toolholder Form B5 right, long

Porte - outil radial Forme B5 droite, long

Radyal kater tutucu B5 Formu sağ, uzun

DIN ISO  
10889  
(DIN  
69880)

DIN ISO  
10889-3

HRC  
52±2

Bestell-Nr. Order Nr. Référence Sipariş Nr.	Abmessung Size / Dimension Size / Cinsi d1 x h1 x L2	L1	h5	h6	b1	b2	b3	Kg	Euro
169.35.12	16 x 12 x 24	13	20	22	58	39	5	0,34	
209.35.16	20 x 16 x 30	16	25	30	75	50	7	0,72	
259.35.16	25 x 16 x 30	16	25	30	75	50	7	0,87	
309.35.20	30 x 20 x 40	22	28	38	100	65	10	1,70	
409.35.25	40 x 25 x 44	22	32,5	48	118	75,5	12,5	3,00	
509.35.32	50 x 32 x 55	30	35	60	130	80	16	5,03	

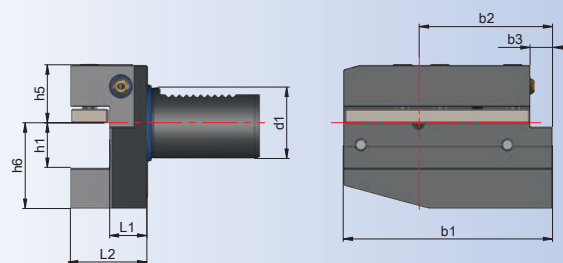

### Zubehör / Accessories / Accessoires / Yedekler



Unterlegplatte  
Shim  
Plaque entretoise  
Kater laması



Kunststoff - Kugelspritzdüse  
Plastic ball sprayer nozzle  
Buse d'injection spherique en plastique  
Su verme misketi



## Radial - Werkzeughalter Form B6 links, lang

B6



Radial - Toolholder Form B6 left, long

Porte - outil radial Forme B6 inversé gauche, long

Radyal kater tutucu B6 Formu sol, uzun

DIN ISO  
10889  
(DIN  
69880)

DIN ISO  
10889-3

HRC  
52±2

Bestell-Nr. Order Nr. Référence Sipariş Nr.	Abmessung Size / Dimension Size / Cinsi d1 x h1 x L2	L1	h5	h6	b1	b2	b3	Kg	Euro
169.36.12	16 x 12 x 24	13	20	22	58	39	5	0,34	
209.36.16	20 x 16 x 30	16	25	30	75	50	7	0,72	
259.36.16	25 x 16 x 30	16	25	30	75	50	7	0,87	
309.36.20	30 x 20 x 40	22	28	38	100	65	10	1,62	
409.36.25	40 x 25 x 44	22	32,5	48	118	75,5	12,5	3,07	
509.36.32	50 x 32 x 55	30	35	60	130	80	16	5,02	

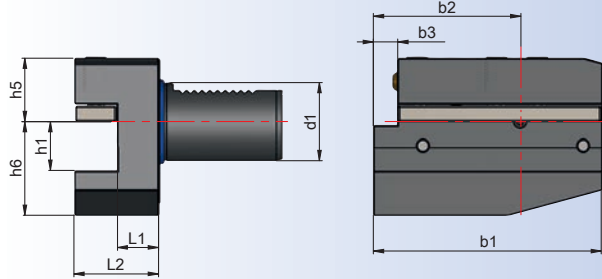

### Zubehör / Accessories / Accessoires / Yedekler



Unterlegplatte  
Shim  
Plaque entretoise  
Kater lamasi



Kunststoff - Kugelspritzdüse  
Plastic ball sprayer nozzle  
Buse d'injection spherique en plastique  
Su verme misketi

## Radial - Werkzeughalter Form B7 Überkopf rechts, lang

B7

Radial - Toolholder Form B7 Overhead right, long

Porte - outil radial Forme B7 inversé droite, long

Radyal kater tutucu B7 Formu kafaüstü sağ, uzun

DIN ISO  
10889  
(DIN  
69880)

DIN ISO  
10889-3

HRC  
52±2

Bestell-Nr. Order Nr. Référence Sipariş Nr.	Abmessung Size / Dimension Size / Cinsi d1 x h1 x L2	L1	h5	h6	b1	b2	b3	Kg	Euro
169.37.12	16 x 12 x 24	13	22	20	58	39	5	0,34	
209.37.16	20 x 16 x 30	16	30	25	75	50	7	0,74	
259.37.16	25 x 16 x 30	16	30	25	75	50	7	0,87	
309.37.20	30 x 20 x 40	22	38	35	100	65	10	1,73	
409.37.25	40 x 25 x 44	22	48	42,5	118	75,5	12,5	3,25	
509.37.32	50 x 32 x 55	30	60	50	130	80	16	5,44	

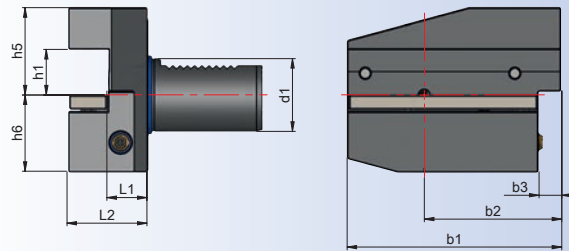

### Zubehör / Accessories / Accessoires / Yedekler



Unterlegplatte  
Shim  
Plaque entretoise  
Kater lamasi



Kunststoff - Kugelspritzdüse  
Plastic ball sprayer nozzle  
Buse d'injection spherique en plastique  
Su verme misketi

DIN ISO 10889  
(DIN 69880)



## Radial - Werkzeughalter Form B8 Überkopf links, lang

B8

Radial - Toolholder Form B8 Overhead left, long

Porte - outil radial Forme B8 inversé gauche, long

Radyal kater tutucu B8 Formu kafaüstü sol, uzun

DIN ISO  
10889  
(DIN  
69880)

DIN ISO  
10889-3

HRC  
52±2

Bestell-Nr. Order Nr. Référence Sipariş Nr.	Abmessung Size / Dimension Size / Cinsi d1 x h1 x L2	L1	h5	h6	b1	b2	b3	Kg	Euro
169.38.12	16 x 12 x 24	13	22	20	58	39	5	0,34	
209.38.16	20 x 16 x 30	16	30	25	75	50	7	0,74	
259.38.16	25 x 16 x 30	16	30	25	75	50	7	0,88	
309.38.20	30 x 20 x 40	22	38	35	100	65	10	1,76	
409.38.25	40 x 25 x 44	22	48	42,5	118	75,5	12,5	3,27	
509.38.32	50 x 32 x 55	30	60	50	130	80	16	5,54	

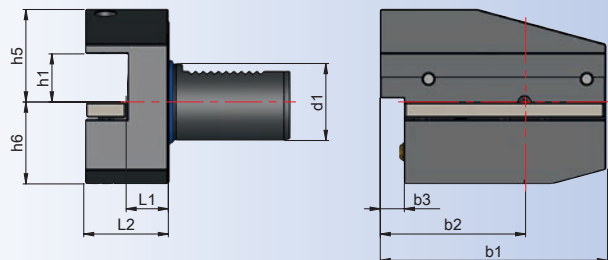

### Zubehör / Accessories / Accessoires / Yedekler



Unterlegplatte  
Shim  
Plaque entretoise  
Kater laması



Kunststoff - Kugelspritzdüse  
Plastic ball sprayer nozzle  
Buse d'injection spherique en plastique  
Su verme misketi

## Axial - Werkzeughalter Form C1 rechts

C1

Axial - Toolholder Form C1 right

Porte - outil Axial Forme C1 droite

Eksenel kater tutucu C1 Formu sağ

DIN ISO  
10889  
(DIN  
69880)

DIN ISO  
10889-4

HRC  
52±2

Bestell-Nr. Order Nr. Référence Sipariş Nr.	Abmessung Size / Dimension Size / Cinsi d1 x h1	L1	L2	h5	h6	b1	b2	b3	Kg	Euro
169.41.12	16 x 12	44	5	20	22	43	24	13	0,44	
209.41.16	20 x 16	50	7	25	30	52	27	13	0,77	
259.41.16	25 x 16	55	7	25	30	58	33	19	1,01	
309.41.20	30 x 20	70	10	28	38	70	35	17	1,66	
409.41.25	40 x 25	85	12,5	32,5	48	85	42,5	21	3,17	
509.41.32	50 x 32	100	16	35	60	100	50	26	5,59	

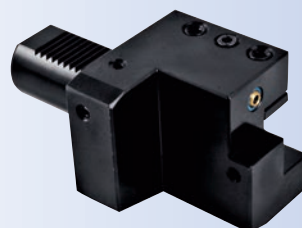
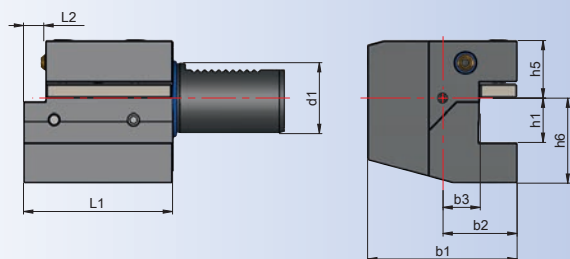

### Zubehör / Accessories / Accessoires / Yedekler



Unterlegplatte  
Shim  
Plaque entretoise  
Kater laması



Kunststoff - Kugelspritzdüse  
Plastic ball sprayer nozzle  
Buse d'injection spherique en plastique  
Su verme misketi



## Axial - Werkzeughalter Form C2 links

C2



Axial - Toolholder Form C2 left

Porte - outil Axial Forme C2 gauche

Eksenel kater tutucu C2 Formu sol

DIN ISO  
10889  
(DIN  
69880)

DIN ISO  
10889-4

HRC  
52±2

Bestell-Nr. Order Nr. Référence Sipariş Nr.	Abmessung Size / Dimension Size / Cinsi d1 x h1	L1	L2	h5	h6	b1	b2	b3	Kg	Euro
169.42.12	16x12	44	5	20	22	43	24	13	0,46	
209.42.16	20x16	50	7	25	30	65	40	26	1,05	
259.42.16	25x16	55	7	25	30	58	33	19	1,01	
309.42.20	30 x 20	70	10	28	38	76	41	23	1,87	
409.42.25	40 x 25	85	12,5	32,5	48	90	47,5	25,5	3,44	
509.42.32	50 x 32	100	16	35	60	105	55	30,5	6,08	

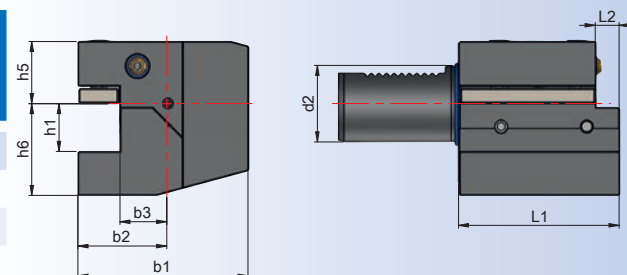

### Zubehör / Accessories / Accessoires / Yedekler



Unterlegplatte  
Shim  
Plaque entretoise  
Kater laması



Kunststoff - Kugelspritzdüse  
Plastic ball sprayer nozzle  
Buse d'injection spherique en plastique  
Su verme misketi

## Axial - Werkzeughalter Form C3 Überkopf rechts, kurz

C3

Axial - Toolholder Form C3 Overhead right, short

Porte - outil Axial Forme C3 inversé droite, court

Eksenel kater tutucu C3 Formu ters sağ, kısa

DIN ISO  
10889  
(DIN  
69880)

DIN ISO  
10889-4

HRC  
52±2

Bestell-Nr. Order Nr. Référence Sipariş Nr.	Abmessung Size / Dimension Size / Cinsi d1 x h1	L1	L2	h5	h6	b1	b2	b3	Kg	Euro
169.43.12	16 x 12	44	5	22	20	43	24	13	0,54	
209.43.16	20 x 16	50	7	30	25	52	27	13	0,79	
259.43.16	25 x 16	55	7	30	25	58	33	19	1,02	
309.43.20	30 x 20	70	10	38	35	70	35	17	1,75	
409.43.25	40 x 25	85	12,5	48	42,5	85	42,5	21	3,45	
509.43.32	50 x 32	100	16	60	50	100	50	26	6,10	

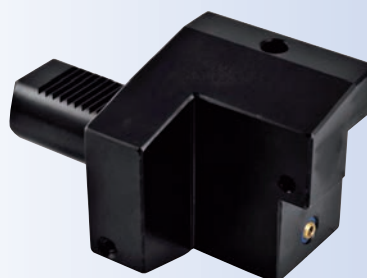
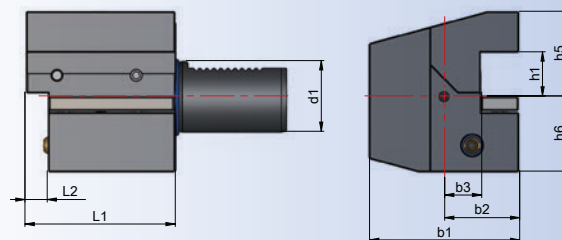

### Zubehör / Accessories / Accessoires / Yedekler



Unterlegplatte  
Shim  
Plaque entretoise  
Kater laması



Kunststoff - Kugelspritzdüse  
Plastic ball sprayer nozzle  
Buse d'injection spherique en plastique  
Su verme misketi

DIN ISO 10889  
(DIN 69880)



## Axial - Werkzeughalter FormC4 Überkopf links, kurz

C4

Axial - Toolholder Form C4 Overhead left, short

Porte - outil Axial Forme C4 inversé gauche, court

Eksenel kater tutucu C4 Formu kafaüstü sol, kısa

DIN ISO  
10889  
(DIN  
69880)

DIN ISO  
10889-4

HRC  
52±2

Bestell-Nr. Order Nr. Référence Sipariş Nr.	Abmessung Size / Dimension Size / Cinsi d1 x h1	L1	L2	h5	h6	b1	b2	b3	Kg	Euro
169.44.12	16 x 12	44	5	22	20	42	24	13	0,54	
209.44.16	20 x 16	50	7	30	25	65	40	26	1,03	
259.44.16	25 x 16	55	7	30	25	58	33	19	1,01	
309.44.20	30 x 20	70	10	38	35	76	41	23	1,98	
409.44.25	40 x 25	85	12,5	48	42,5	90	47,5	25,5	3,70	
509.44.32	50 x 32	100	16	60	50	105	55	30,5	6,40	

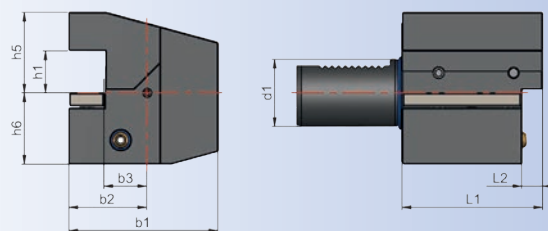

### Zubehör / Accessories / Accessoires / Yedekler



Unterlegplatte  
Shim  
Plaque entretoise  
Kater laması



Kunststoff - Kugelspritzdüse  
Plastic ball sprayer nozzle  
Buse d'injection spherique en plastique  
Su verme misketi

## Vierkant - Aufnahme, Form D1

D1

Squaretool holder, Form D1

Tige carre, Forme D1

Çok yönlü kater tutucu, D1 Formu

DIN ISO  
10889  
(DIN  
69880)

DIN ISO  
10889-5

HRC  
52±2

Bestell-Nr. Order Nr. Référence Sipariş Nr.	Abmessung Size / Dimension Size / Cinsi d1 x h1	L1	L2	h3	h4	b1	b3	Kg	Euro
259.55.16	25 x 16	34	48	25	30	33	33	1,24	
309.55.20	30 x 20	42	60	28	38	35	41	1,97	
409.55.25	40 x 25	50	72	32,5	48	42,5	47,5	3,87	
509.55.32	50 x 32	60	85	35	60	50	55	6,48	

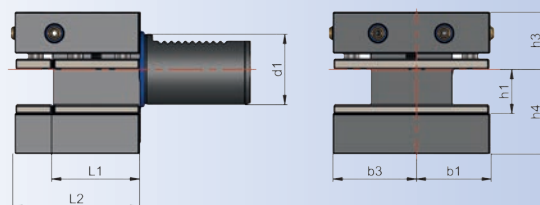

## Vierkant - Aufnahme, Überkopf, Form D2

D2



Squaretool holder, inverted, Form D2

Tige carre, al'envers, Forme D2

Çok yönlü kater tutucu, D2 Formu

DIN ISO  
10889  
(DIN  
69880)

DIN ISO  
10889-5

HRC  
52±2

Bestell-Nr. Order Nr. Référence Sipariş Nr.	Abmessung Size / Dimension Size / Cinsi d1 x h1	L1	L2	h3	h4	b1	b3	Kg	Euro
259.56.16	25 x 16	34	48	30	25	33	33	1,25	
309.56.20	30 x 20	42	60	38	35	35	41	2,21	
409.56.25	40 x 25	50	72	48	42,5	42,5	42,5	4,22	
509.56.32	50 x 32	60	85	60	50	50	55	7,56	

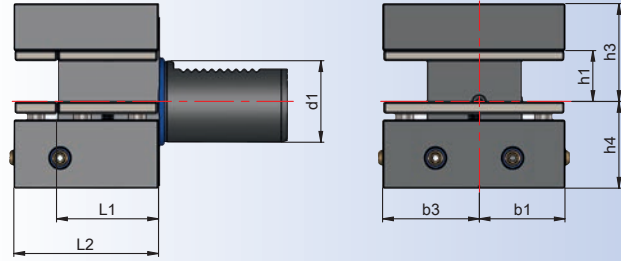

## Bohrerhalter für Wendepplattenbohrer E1

E1

Boring holder for drill with indexable insert form E1

Porte foret pour foret à plaquettes réversible forme E1

Takma uçlu drill tutucu E1 Formu

DIN ISO  
10889  
(DIN  
69880)

DIN ISO  
10889-6

HRC  
52±2



ISO 9766



Bestell-Nr. Order Nr. Référence Sipariş Nr.	Abmessung Size / Dimension Size / Cinsi d1 x d2	A	L3	h1	h2	d3	d6	Kg	Euro
209.51.16.67	20 x 16	67	18	23	23	36	50	0,65	
209.51.20.67	20 x 20	67	18	23	23	40	50	0,69	
209.51.25.71	20 x 25	71	18	23	23	45	50	0,75	
259.51.16.67	25 x 16	67	18	25	25	36	58	0,78	
259.51.20.67	25 x 20	67	18	25	25	40	58	0,83	
259.51.25.71	25 x 25	71	18	25	25	45	58	0,91	

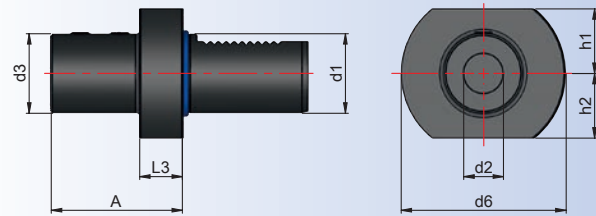

## Zubehör / Accessories / Accessoires / Yedekler

DIN 913



Spannschrauben  
Clamping screw  
Vis de serrage  
Sıkma civatası

10.39 - 10.40

DIN ISO 10889  
(DIN 69880)



## Bohrerhalter für Wendepplattenbohrer E1

E1

Boring holder for drill with indexable insert form E1

Porte foret pour foret à plaquettes réversible forme E1

Takma uçlu drill tutucu E1 Formu

DIN ISO  
10889  
(DIN  
69880)

DIN ISO  
10889-6

HRC  
52±2

H4

ISO 9766



Bestell-Nr. Order Nr. Référence Sipariş Nr.	Abmessung Size / Dimension Size / Cinsi d1 x d2	A	L3	h1	h2	d3	d6	Kg	Euro
309.51.16.64	30 x 16	64	22	28	30	36	68	1,01	
309.51.20.67	30 x 20	67	22	28	30	40	68	1,09	
309.51.25.71	30 x 25	71	22	28	30	45	68	1,13	
309.51.32.75	30 x 32	75	22	28	30	52	68	1,26	
309.51.40.95	30 x 40	95	22	28	30	63	68	1,59	
409.51.16.64	40 x 16	64	22	32,5	-	36	83	1,63	
409.51.20.67	40 x 20	67	22	32,5	-	40	83	1,67	
409.51.25.75	40 x 25	75	22	32,5	-	45	83	1,77	
409.51.32.75	40 x 32	75	22	32,5	-	52	83	1,84	
409.51.40.90	40 x 40	90	22	32,5	-	63	83	2,34	
509.51.16.66	50 x 16	66	30	35	-	36	98	2,94	
509.51.20.67	50 x 20	67	30	35	-	40	98	3,03	
509.51.25.80	50 x 25	80	30	35	-	45	98	2,94	
509.51.32.80	50 x 32	80	30	35	-	52	98	3,02	
509.51.40.90	50 x 40	90	30	35	-	63	98	3,38	
509.51.50.100	50 x 50	100	30	35	-	75	98	3,60	

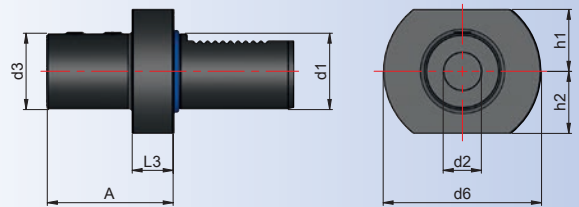

## Zubehör / Accessories / Accessoires / Yedekler

DIN 913



Spannschrauben  
Clamping screw  
Vis de serrage  
Sıkma civatası

10.39 - 10.40



## Boring bar holder Form E2

## Porte-outil pour barred d'alésage Forme E2

## İç çap tornalama kater tutucu E2 Formu

DIN ISO  
10889  
(DIN  
69880)DIN ISO  
10889-6HRC  
52±2

H7

Bestell-Nr. Order Nr. Référence Sipariş Nr.	Abmessung Size / Dimension Size / Cinsi d1 x d2	A	L3	h1	h2	d3	d6	Kg	Euro
169.52.06.44	16 x 06	44	13	18	18	32	40	0,33	
169.52.08.44	16 x 08	44	13	18	18	32	40	0,32	
169.52.10.44	16 x 10	44	13	18	18	32	40	0,31	
169.52.12.44	16 x 12	44	-	18	18	40	40	0,40	
169.52.16.44	16 x 16	44	-	18	18	40	40	0,37	

209.52.08.50	20 x 08	50	18	23	23	40	50	0,61	
209.52.10.50	20 x 10	50	18	23	23	40	50	0,60	
209.52.12.50	20 x 12	50	18	23	23	40	50	0,59	
209.52.16.50	20 x 16	50	18	23	23	40	50	0,56	
209.52.20.50	20 x 20	50	-	23	23	50	50	0,69	
209.52.25.60	20 x 25	60	-	23	23	50	50	0,75	

259.52.08.50	25 x 08	50	18	25	25	40	58	0,76	
259.52.10.50	25 x 10	50	18	25	25	40	58	0,76	
259.52.12.50	25 x 12	50	18	25	25	40	58	0,75	
259.52.16.50	25 x 16	50	18	25	25	40	58	0,71	
259.52.20.50	25 x 20	50	-	25	25	58	58	1,00	
259.52.25.60	25 x 25	60	-	25	25	58	58	1,10	

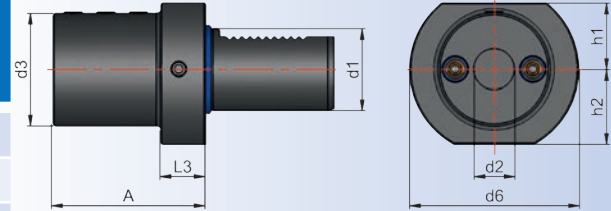
DIN ISO 10889  
(DIN 69880)

## Zubehör / Accessories / Accessoires / Yedekler



Reduzierbuchsen  
Reducing sleeve  
Douilles de reduction  
Redüksiyon



DIN 913

Spannschrauben  
Clamping screw  
Vis de serrage  
Skma civatası



10.50

Kunststoff - Kugelspritzdüse  
Plastic ball sprayer nozzle  
Buse d'injection spherique en plastique  
Su verme misketi



## Bohrerhalter Form E2

E2

### Boring bar holder Form E2

### Porte-outil pour barred d'alésage Forme E2

### Delik kater tutucu E2 Formu

DIN ISO  
10889  
(DIN  
69880)

DIN ISO  
10889-6

HRC  
52±2

H7

Bestell-Nr. Order Nr. Référence Sipariş Nr.	Abmessung Size / Dimension Size / Cinsi d1 x d2	A	L3	h1	h2	d3	d6	Kg	Euro
309.52.08.60	30 x 08	60	22	28	30	55	68	1,43	
309.52.10.60	30 x 10	60	22	28	30	55	68	1,38	
309.52.12.60	30 x 12	60	22	28	30	55	68	1,35	
309.52.16.60	30 x 16	60	22	28	30	55	68	1,36	
309.52.20.60	30 x 20	60	22	28	30	55	68	1,34	
309.52.25.60	30 x 25	60	22	28	30	55	68	1,22	
309.52.32.75	30 x 32	75	22	28	30	66	68	1,63	
309.52.40.90	30 x 40	90	22	32	30	66	68	1,78	
409.52.08.75	40 x 08	75	22	32,5	-	55	83	2,28	
409.52.10.75	40 x 10	75	22	32,5	-	55	83	2,26	
409.52.12.75	40 x 12	75	22	32,5	-	55	83	2,23	
409.52.16.75	40 x 16	75	22	32,5	-	55	83	2,22	
409.52.20.75	40 x 20	75	22	32,5	-	55	83	2,16	
409.52.25.75	40 x 25	75	22	32,5	-	55	83	2,07	
409.52.32.75	40 x 32	75	-	32,5	-	83	83	3,01	
409.52.40.90	40 x 40	90	-	32,5	-	83	83	3,24	
509.52.12.90	50 x 12	90	30	35	-	68	98	4,13	
509.52.16.90	50 x 16	90	30	35	-	68	98	4,07	
509.52.20.90	50 x 20	90	30	35	-	68	98	4,00	
509.52.25.90	50 x 25	90	30	35	-	68	98	3,88	
509.52.32.90	50 x 32	90	30	35	-	68	98	3,68	
509.52.40.90	50 x 40	90	-	35	-	98	98	4,93	
509.52.50.100	50 x 50	100	-	35	-	98	98	5,09	

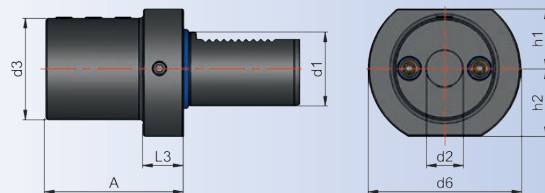

### Zubehör / Accessories / Accessoires / Yedekler



Reduzierbuchsen  
Reducing sleeve  
Douilles de reduction  
Redüksiyon



DIN 913

10.39-10.40

Spannschrauben  
Clamping screw  
Vis de serrage  
Sıkma civatası



Kunststoff - Kugelspritzdüse  
Plastic ball sprayer nozzle  
Buse d'injection spherique en plastique  
Su verme misketi





## Collet holder Form E3 for Collets

## Porte-outil Forme E3 pour pinces de serrage

## Pens başlığı E3 Formu pens

DIN ISO  
10889  
(DIN  
69880)DIN ISO  
10889-6DIN ISO  
10897HRC  
52±2

Bestell-Nr. Order Nr. Référence Sipariş Nr.	Abmessung Size / Dimension Size / Cinsi d1 x d2	A	L2	L3	h1	h2	d6	d10	Kg	Euro
169.01.16.57	16 x OZ (2 -16)	57	51	13	18	18	40	43	0,38	
209.01.16.57	20 x OZ (2 -16)	57	51	18	23	23	50	43	0,55	
259.01.16.57	25 x OZ (2 -16)	57	51	18	25	25	58	43	0,68	
309.01.16.57	30 x OZ (2 -16)	57	51	22	28	30	68	43	0,94	
309.01.25.75	30 x OZ (2 -25)	75	64	22	28	30	68	60	1,31	
409.01.16.55	40 x OZ (2 -16)	55	51	22	32,5	-	83	43	1,48	
409.01.25.75	40 x OZ (2 -25)	75	64	22	32,5	-	83	60	1,97	
409.01.32.90	40 x OZ (4 -32)	90	74	22	32,5	-	83	72	2,36	
509.01.25.75	50 x OZ (2 -25)	75	64	30	35	-	98	60	3,05	
509.01.32.90	50 x OZ (4 -32)	90	74	30	35	-	98	72	3,53	

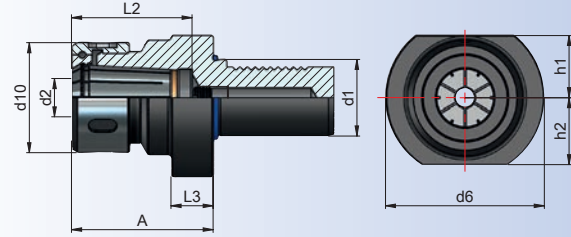
DIN ISO 10889  
(DIN 69880)

## Zubehör / Accessories / Accessoires / Yedekler

Spannzangen OZ  
Collets OZ  
Pincés de serrage OZ  
Pens OZSpannmutter OZ  
Clamping nuts OZ  
Écrou de serrage OZ  
Pens kapığı OZHakenschlüssel  
Wrench  
Clé à ergot  
E tipi ay anahtar



## Spannfutter Form E4 für Spannzangen ER

E4

Collet holder Form E4 for Collets Type ER

Porte-outil Forme E4 pour pinces de serrage Type ER

Pens başlığı E4 Formu pens ER Tipi

DIN ISO  
10889  
(DIN  
69880)

DIN ISO  
10889-6

DIN ISO  
15488

HRC  
52±2

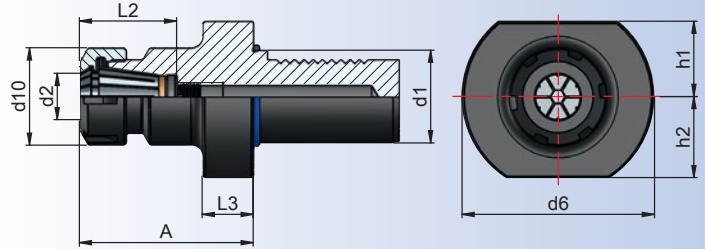

Bestell-Nr. Order Nr. Référence Sipariş Nr.	Abmessung Size / Dimension Size / Cinsi d1 x d2	A	L2	L3	h1	h2	d6	d10	Kg	Euro
169.02.10.50	16 x ER16 (1-10)	50	32	13	18	18	40	28	0,27	
169.02.16.48	16 x ER25 (2-16)	48	42	13	18	18	40	42	0,31	
209.02.10.55	20 x ER16 (1-10)	55	32	18	23	23	50	28	0,45	
209.02.16.57	20 x ER25 (2-16)	57	49	18	23	23	50	42	0,53	
209.02.20.58	20 x ER32 (2-20)	58	50	18	23	23	50	50	0,56	
259.02.16.57	25 x ER25 (2-16)	57	42	18	25	25	58	42	0,69	
309.02.16.57	30 x ER25 (2-16)	57	46	22	28	30	68	42	0,95	
309.02.20.75	30 x ER32 (2-20)	75	48	22	28	30	68	50	1,22	
309.02.26.75	30 x ER40 (3-26)	75	58	22	28	30	68	63	1,29	
409.02.16.75	40 x ER25 (2-16)	75	42	22	32,5	-	83	42	1,66	
409.02.20.75	40 X ER32 (2-20)	75	48	22	32,5	-	83	50	1,77	
409.02.26.75	40 X ER40 (3-26)	75	58	22	32,5	-	83	63	1,99	
509.02.26.75	50 x ER40 (3-26)	75	58	30	35	-	98	63	3,06	



ER 16

## Zubehör / Accessories / Accessoires / Yedekler



DIN ISO  
15488

10.11 - 10.18

Spannzangen System ER  
Collets System ER  
Pinces de serrage System ER  
Pens ER



DIN ISO  
15488

10.25 - 10.26

Spannmutter ER  
Clamping nuts ER  
Écrou de serrage ER  
Pens kapağı ER



10.48

Spannschlüssel für ER  
Wrench ER  
Clé de serrage ER  
Anahtar ER



i

11.01



## Holder for morse taper Shanks Form F1

## Porte-foret pour outil à cône Morse Forme F1

## Mors konik tutucu F1 Formu

DIN ISO  
10889  
(DIN  
69880)DIN ISO  
10889-7DIN  
228HRC  
52±2

Bestell-Nr. Order Nr. Référence Sipariş Nr.	Abmessung Dimension Size / Cinsi d1 x MK	A	L3	h1	h2	d4	d6	Kg	Euro
169.07.01.32	16 x MK1	32	13	18	18	32	40	0,29	
209.07.01.23	20 x MK1	23	-	23	23	-	50	0,37	
209.07.02.90	20 x MK2	90	30	23	23	40	50	1,24	
259.07.01.23	25 x MK1	23	-	25	25	-	58	0,55	
259.07.02.27	25 x MK2	27	-	25	25	-	58	0,56	
309.07.01.27	30 x MK1	27	-	28	30	-	68	0,89	
309.07.02.27	30 x MK2	27	-	28	30	-	68	0,83	
309.07.03.66	30 x MK3	66	22	28	30	58	68	1,42	
409.07.01.36	40 x MK1	36	22	32,5	-	55	83	1,60	
409.07.02.36	40 x MK2	36	22	32,5	-	55	83	1,52	
409.07.03.36	40 x MK3	36	22	32,5	-	58	83	1,43	
409.07.04.80	40 x MK4	80	22	32,5	-	68	83	2,40	
509.07.02.36	50 x MK2	36	30	35	-	55	98	2,62	
509.07.03.36	50 x MK3	36	30	35	-	58	98	2,47	
509.07.04.50	50 x MK4	50	30	35	-	68	98	2,61	

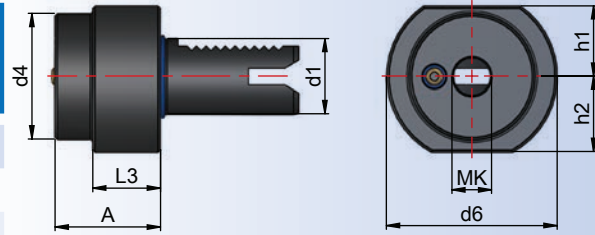
DIN ISO 10889  
(DIN 69880)

## Zubehör / Accessories / Accessoires / Yedekler



Kunststoff - Kugelspritzdüse  
Plastic ball sprayer nozzle  
Buse d'injection spherique en plastique  
Su verme misketi

10.50



## NC - Bohrfutter mit zentraler Kühlmittelzuführung

NC-Drill chucks with center coolant

Mandrin de perçage CNC avec arrosage par to centre

NC tipi mandren malafası, merkezden su vermeli

DIN ISO  
10889  
(DIN  
69880)

HRC  
52±2

h6

Bestell-Nr. Order Nr. Référence Sipariş Nr.	Spannbereich Capacity Capacité Kapasite	A	D	L3	d1	A1 Max.	Kg	Euro
209.15.08.68	0,5 - 8	68	36	18	20	71	1,15	
209.15.13.90	1,0 - 13	90	50	18	20	98	1,26	
259.15.13.89	1,0 - 13	89	50	18	25	97	1,37	
309.15.08.69	0,5 - 8	69	36	19	30	72	1,00	
309.15.13.90	1,0 - 13	90	50	19	30	98	1,65	
309.15.16.95	3,0 - 16	95	57	19	30	100	1,81	
409.15.13.90	1,0 - 13	90	50	20	40	98	2,19	
409.15.16.95	3,0 - 16	95	57	20	40	100	2,43	
509.15.13.100	1,0 - 13	100	50	30	50	108	3,53	
509.15.16.106	3,0 - 16	106	57	30	50	111	3,73	

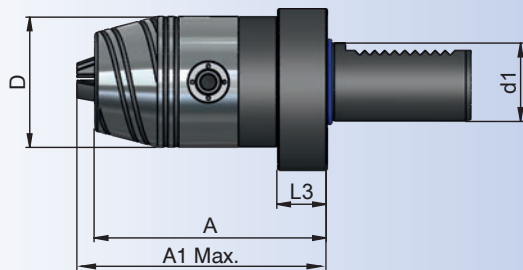

### Zubehör / Accessories / Accessoires / Yedekler



10.55-10.57

Ersatzteile  
Spare Parts  
Pièce de rechange  
Yedek parçalar



10.49

Spannschlüssel  
Wrench  
Clé de serrage  
Sıkma anahtarı



11.06

## NC - Bohrfutter mit Kühlmittelzuführung über Kugelspritzdüsen

NC-Drill chucks with coolant supply via ball coolant nozzle

Mandrin de perçage CNC avec arrosage par buses de picot

NC tipi mandren malafası, alından soğutma suyu püskürtmeli

DIN ISO  
10889  
(DIN  
69880)

HRC  
52±2

h6

Bestell-Nr. Order Nr. Référence Sipariş Nr.	Spannbereich Capacity Capacité Kapasite	A	D	L3	d1	A1 Max.	Kg	Euro
309.15.13.90.K	1,0 - 13	90	57	20	30	98	1,88	
309.15.16.95.K	3,0 - 16	95	57	20	30	100	1,98	
409.15.13.90.K	1,0 - 13	90	57	20	40	98	2,48	
409.15.16.95.K	3,0 - 16	95	57	20	40	100	2,45	

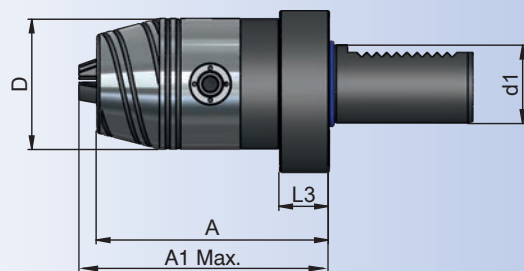

### Zubehör / Accessories / Accessoires / Yedekler



10.55-10.57

Ersatzteile  
Spare Parts  
Pièce de rechange  
Yedek parçalar



10.49

Spannschlüssel  
Wrench  
Clé de serrage  
Sıkma anahtarı



11.06

## Gewindeschneid - Schnellwechselfutter mit Längenausgleich auf Druck und Zug



### Quick-change tapping chucks with length compensation

### Appareil à tarauder avec compensation longitudinale

### Kılavuz çekme başlığı giriş ve çıkış kompanzeli

DIN ISO  
10889  
(DIN  
69880)

HRC  
52±2

Bestell-Nr. Order Nr. Référence Sipariş Nr.	Spannbereich Capacity Capacité Kapasite	d	A	D	d1	C	T	Kg	Euro
209.16.12.57	M2-M14	19	57	38	20	7	7	0,49	
259.16.12.58	M2-M14	19	58	38	25	7	7	0,77	
309.16.12.62	M2-M14	19	62	38	30	7	7	0,99	
309.16.20.84	M5-M24	31	84	54	30	12	12	1,43	
409.16.12.62	M2-M14	19	62	38	40	7	7	1,57	
409.16.20.84	M5-M24	31	84	54	40	12	12	2,00	
509.16.12.70	M2-M14	19	70	38	50	7	7	3,04	
509.16.20.92	M5-M24	31	92	54	50	12	12	3,21	
509.16.36.108	M14-M36	48	108	78	50	17,5	17,5	3,90	

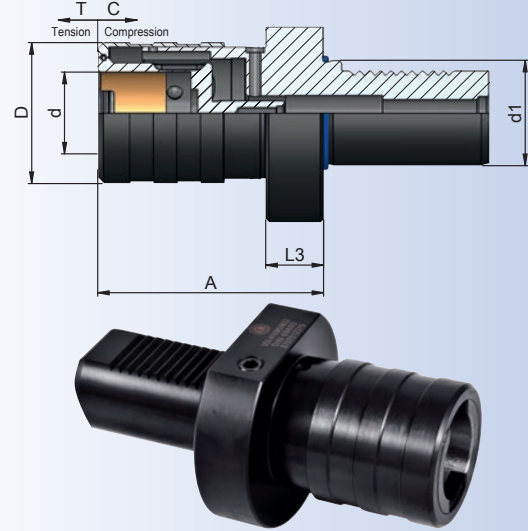

### Zubehör / Accessories / Accessoires / Yedekler



Schnellwechseleinsätze  
Tapping collets  
Douilles de taraudage  
Kılavuz tutucu

Ausführung : Mit Kugelführungsbuchse  
Version : With ball retainer  
Version : Comprenant douille de glissière à bille  
Teknik özelliği : Bilya Kafesli

## Gewindeschneid - Schnellwechselfutter ohne Längenausgleich auf Druck und Zug

### Quick-change tapping chucks without length compensation

### Appareil à tarauder sans compensation longitudinale

### Kılavuz çekme başlığı sabit

DIN ISO  
10889  
(DIN  
69880)

HRC  
52±2

Bestell-Nr. Order Nr. Référence Sipariş Nr.	Spannbereich Capacity Capacité Kapasite	d	A	D	d1	Kg	Euro
209.16.12.1.58	M2-M14	19	58	38	30	0,58	
259.16.12.1.58	M2-M14	19	58	38	25	0,82	
309.16.12.1.62	M2-M14	19	62	38	30	1,01	
309.16.20.1.85	M5-M24	31	85	52	30	1,44	
409.16.12.1.62	M2-M14	19	62	38	40	1,65	
409.16.20.1.85	M5-M24	31	85	52	40	2,12	
509.16.12.1.72	M2-M14	19	72	38	50	3,01	
509.16.20.1.93	M5-M24	31	93	52	50	3,39	
509.16.36.1.116	M14-M36	48	116	78	50	4,60	

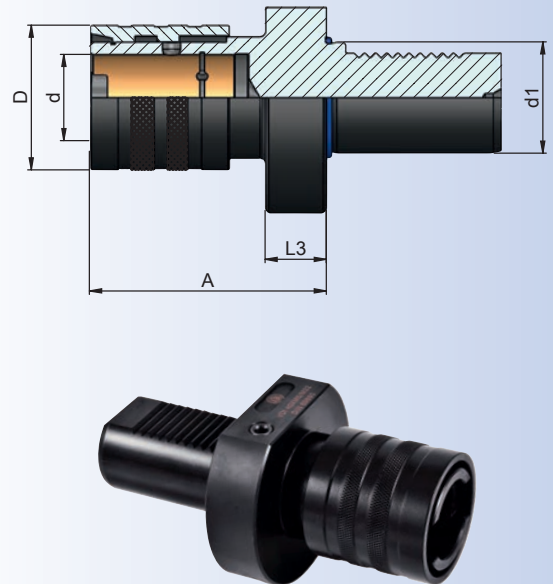

### Zubehör / Accessories / Accessoires / Yedekler



Schnellwechseleinsätze  
Tapping collets  
Douilles de taraudage  
Kılavuz tutucu

DIN ISO 10889  
(DIN 69880)



## Kontrolldorne

### Test arbors

### Mandrins de contrôle

### Kontrol mastarı

DIN ISO  
10889  
(DIN  
69880)

HRC  
52±2

Bestell-Nr. Order Nr. Référence Sipariş Nr.	D	A	L	d1	Kg	Euro
169.18.30.120	30	120	107	16	0,75	
209.18.40.150	40	150	132	20	1,64	
259.18.40.150	40	150	132	25	1,80	
309.18.40.200	40	200	178	30	2,59	
409.18.40.200	40	200	178	40	3,17	
509.18.40.200	40	200	170	50	4,36	

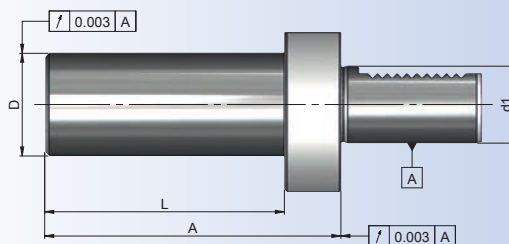

Verwendung : Zur Abnahme von Werkzeugmaschinen  
gemäß ISO-Empfehlung R230

Application : For acceptance tests of machine tools  
in accordance with ISO-recommendation R230

Application : Pour la recette technique des machines  
conforme recommandation ISO R230

Açıklama : Tezgahları devreye alırken ISO Normu R230  
sisteminde uygunluğunu kontrol etmek için

## Einrichtehalter

### Setting-holder

### Porte-outil de réglage

### Fener mili pozisyon kontrol mastarı

DIN ISO  
10889  
(DIN  
69880)

HRC  
52±2

Bestell-Nr. Order Nr. Référence Sipariş Nr.	A	D	L	d1	Kg	Euro
409.19.40.100	100	40	85	40	2,15	

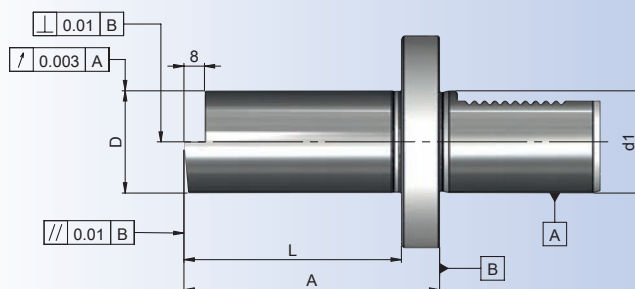

Verwendung : Zur Abnahme von Werkzeugmaschinen  
gemäß ISO-Empfehlung R230

Application : For acceptance tests of machine tools  
in accordance with ISO-recommendation R230

Application : Pour la recette technique des machines  
conforme recommandation ISO R230

Açıklama : Tezgahları devreye alırken ISO Normu R230  
sisteminde uygunluğunu kontrol etmek için



## Hydro - Dehnspanfutter



### Hydraulic expansions chuck

### Mandrins expansibles hydrauliques

### Hidrolik takım tutucular

DIN ISO  
10889  
(DIN  
69880)

HRC  
52+2



h6

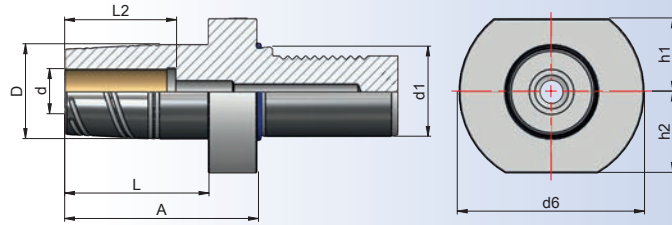

Bestell-Nr. Order Nr. Référéncé Sipariş Nr.	Abmessung Size/Dimension Size/Cinsi d1 x d	A	D	L2	h1	h2	L	d6	Kg	Euro
259.65.12.55	25 x 12	55	32	46	25	25	37	58	0,67	
309.65.12.55	30 x 12	55	32	46	28	30	33	68	0,94	
309.65.20.64	30 x 20	64	42	51	28	30	42	68	1,03	
409.65.12.60	40 x 12	60	32	46	32,5	-	38	83	1,68	
409.65.20.64	40 x 20	64	42	51	32,5	-	42	83	1,67	
509.65.20.75	50 x 20	75	42	51	35	-	45	98	3,07	
509.65.32.85	50 x 32	85	63	57	35	-	55	98	3,61	



DIN ISO 10889  
(DIN 69880)

### Zubehör / Accessories / Accessoires / Yedekler



Reduzierungen  
Reducing arbor  
Douille de réduction  
Pens



DIN 916

Einstellschraube  
Adjusting screw  
Vis de réglage  
Dayama civatası



10.49

Spannschlüssel  
Wrench  
Clé de serrage  
Sıkma anahtarı



10.48

Büchsenzieher für Reduzierungen  
Sleeve remover for reducing arbor  
Clé étrépage pour douilles  
Hidrolik Takım Pensi Çıkarma Anahtarı

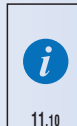

11.10



## Schutzstopfen Z2 Kunststoff

Z2

Protective plug Z2, plastic

Bouchon de protection Z2, plastique

Plastik kör tapa, Z2 Formu

DIN ISO  
10889  
(DIN  
69880)

DIN ISO  
10889-8

Bestell-Nr. Order Nr. Référence Sipariş Nr.	A	D	d1	Kg	Euro
169.28.13	13	40	16	0,12	
209.28.16	16	50	20	0,14	
259.28.16	16	58	25	0,08	
309.28.20	20	68	30	0,20	
409.28.20	20	83	40	0,15	
509.28.20	20	98	50	0,29	

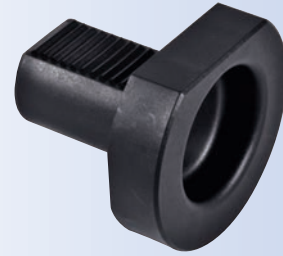
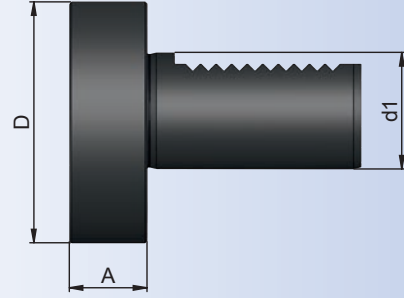

## Schutzstopfen Z2 Stahl

Z2

Protective plug Z2, steel

Bouchon de protection Z2, acier

Metal kör tapa, Z2 Formu

DIN ISO  
10889  
(DIN  
69880)

DIN ISO  
10889-8

HRC  
52±2

Bestell-Nr. Order Nr. Référence Sipariş Nr.	A	D	d1	Kg	Euro
169.29.13	13	40	16	0,16	
209.29.16	16	50	20	0,33	
259.29.16	16	58	25	0,50	
309.29.20	20	68	30	0,80	
409.29.20	20	83	40	1,36	
509.29.20	20	98	50	2,27	

